



MODEL 1029 Quick Reference

Undermount
Center Mount
3/4 Extension

APPLICATIONS: Use model 1029 whenever a center under mount, three-quarter extension slide is required. Use for kitchen, bath, and residential applications.

Over all dimensions: 1.38" W x .38" T
Load Rating: 35 lbs**
Lengths: 13" - 27"

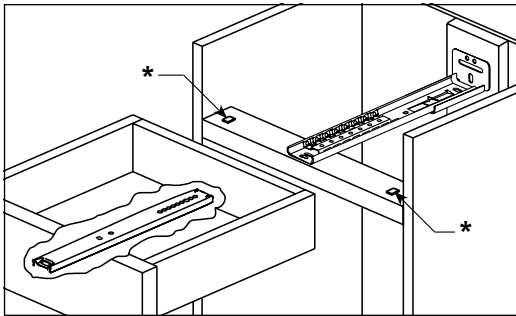

Tack
P/N 2336-2738-YE
(2 Ea. Per Slide)

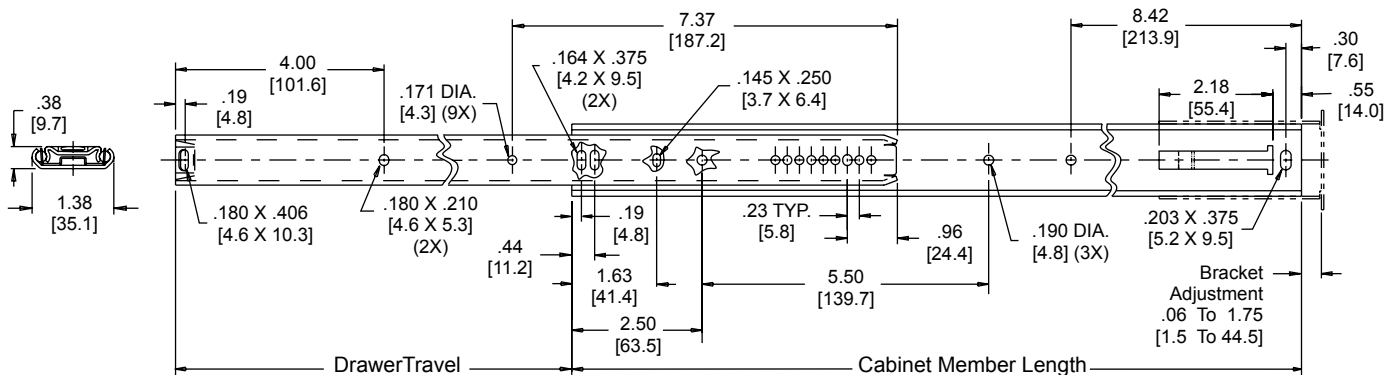
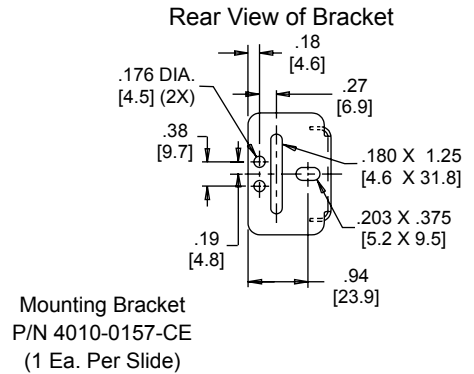
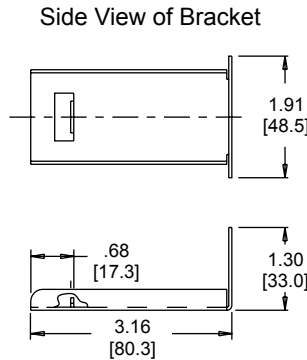

INCHES
[mm]

- Finishes** Bright electro-zinc (C) or black zinc (CB)
- Lengths** 13" to 27" [330mm to 686mm]
- Travel** See chart
- Load** 35 lbs.** [16 kg.]
- Disconnect** Friction disconnect
- Hardware** #8 slotted pan or slotted binding head screws
- Movement** Steel ball bearings
- Ordering Instructions** Measure the drawer from the rear of the front panel to the rear of the back of the drawer. Using the drawer measurement, select slide from chart at right. Measure your cabinet depth and check it against tabulation for selected slide.
Example: 17" [432mm] long drawer with 20" [508mm] cabinet, zinc finish, order C1029-119.

Part Number	Fits Drawer Lengths	Fits Cabinet Depths	Cabinet Member Lengths	Drawer Travel
1029-113	10-5/8" to 12-1/2" [269.9 to 317.5]	13" to 14-1/2" [330.2 to 368.3]	12-7/8" [327.0]	8-1/2" [215.9]
1029-115	12-5/8" to 14-1/2" [320.7 to 368.3]	15" to 16-1/2" [381.0 to 419.1]	14-7/8" [377.8]	10-1/2" [266.7]
1029-117	14-5/8" to 16-1/2" [371.5 to 419.1]	17" to 18-1/2" [431.8 to 469.9]	16-7/8" [428.6]	12" [304.8]
1029-119	16-5/8" to 18-1/2" [422.3 to 469.9]	19" to 20-1/2" [482.6 to 520.7]	18-7/8" [479.4]	12-1/2" [317.5]
1029-121	18-5/8" to 20-1/2" [473.1 to 520.7]	21" to 22-1/2" [533.4 to 571.5]	20-7/8" [530.2]	15" [381.0]
1029-123	20-5/8" to 22-1/2" [523.9 to 571.5]	23" to 24-1/2" [584.2 to 622.3]	22-7/8" [581.0]	16-1/2" [419.1]
1029-125	22-5/8" to 24-1/2" [574.7 to 622.3]	25" to 26-1/2" [635.0 to 673.1]	24-7/8" [631.8]	17-1/2" [444.5]
1029-127	24-5/8" to 26-1/2" [625.5 to 673.1]	27" to 28-1/2" [685.8 to 723.9]	26-7/8" [682.6]	19-1/2" [495.3]

Features Optional rear mounting bracket adjusts to fit various cabinet depths. Rear plastic socket and roller are optional and available directly from **Bainbridge Manufacturing Company** at (509) 745-9555.

** Load rating is based on an 18" side in a 16" wide drawer cycled 50,000 times.

To use model 1029 center slide, the drawer side must extend below the drawer bottom 1/4" [6.4mm]. See Figure 1. It may be necessary to cut a notch in the back overhang of the drawer, allowing the slide to fully extend to the back of the cabinet.

NOTE: A shim should be used below the cabinet member to compensate for required drawer clearance. The thickness of the shim should provide sufficient clearance between the drawer bottom and bottom of the drawer side after the tacks have been installed.

Example: 3/8" [9.5mm] drawer side would require a 1/8" [3.2mm] shim. See Figure 2.

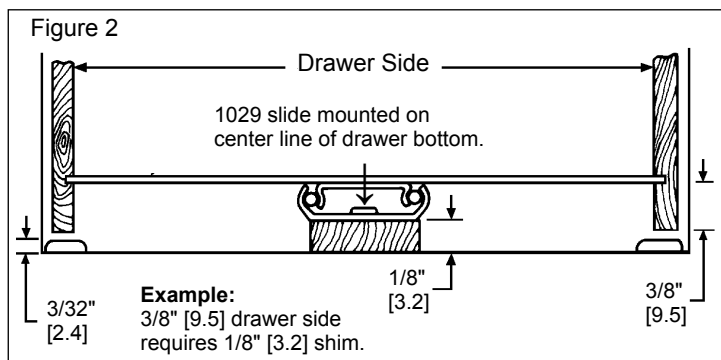
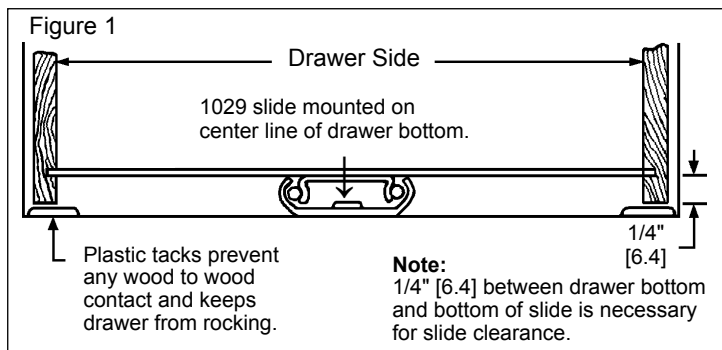

Drawer Member

1. Open the slide and separate the drawer and cabinet members by pulling firmly through the friction resistance.
2. Measure and mark the center line of the drawer width and the cabinet opening. Notch drawer back as required. See Figure 3
3. Mount the drawer member (narrow member) under the drawer centerline. See Figure 3. Install a #8 pan head screw through the sloped slot so the front of the drawer member is flush with the rear of the drawer front panel. Select a hole nearest the center of the drawer back at its thickest point and install a #8 pan head screw.

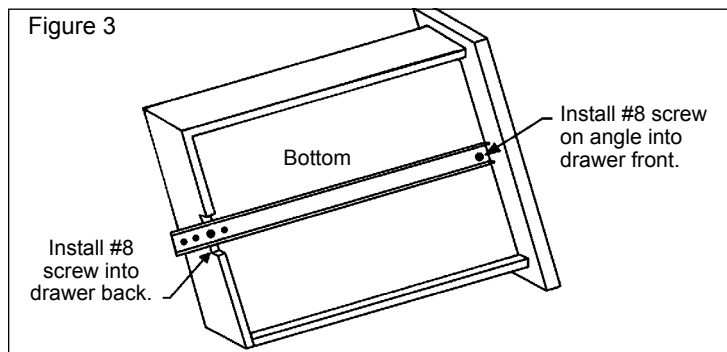

Cabinet Member

With Rear Adjustable Bracket

4. At the rear of the cabinet, locate a point on the centerline of the cabinet opening and 13/16" above the cross rail. Install a #8 screw through the horizontal slot in the bracket. **Do not tighten completely.** Assemble cabinet member to the bracket and extend member to cabinet front and mount to predetermined center line of cabinet cross rail.

Without Rear Adjustable Bracket

If cabinet has a horizontal stringer, mount directly through holes provided. Secure #8 screws to stringer.

5. Install plastic headed glide tacks in front face frame so drawer sides are supported. See Figure 1.
6. Move the ball bearing retainer completely forward. Carefully engage the drawer member into cabinet until it is completely closed. Secure the "rear adjustable bracket" (if necessary) so the front drawer panel closes flush with the cabinet.
7. After all adjustments have been made, securely tighten all screws. A round hole is provided in the rear bracket to accommodate a fixing screw.

Slide Ordering Instructions

Complete your order for Accuride center mount slide 1029 by specifying the following:

Total slides required 100 Each C 1029 -117 D
 Finish _____
 Model _____
 Length _____
 Optional polybag packaging _____

Packaging

Distributor (D) Pack

Polybag packaging includes 1 slide, 1 rear adjustable bracket, 2 tacks, and 5 screws. All lengths are packaged 20 each per box.

Express (X) Pack

Slides, rear adjustable brackets, and tacks are packed in one box. All lengths are packaged 20 each per box.

Bulk (P) Pack

Slides, rear adjustable brackets, and tacks are ordered and packaged separately. Slides may be purchased without brackets and tacks.

Lengths -113 through -119	50 each per box
Lengths -121	40 each per box
Lengths -123 through -127	25 each per box

Specifications

Slide members and ball retainers: Cold rolled steel
 Ball bearings: Carburized steel
 RoHs Compliant

NOTE: Specifications, materials, prices, terms, and delivery are subject to change without notice.

Accuride[®]
 ACCURIDE INTERNATIONAL INC.

12311 Shoemaker Avenue
 Santa Fe Springs, CA 90670
 TEL (562) 903-0200
 FAX (562) 903-0208
 www.accuride.com
 Manufacturing, Engineering, and Sales
 United States • Germany • Japan • Mexico • United Kingdom • China